



**G2000**  
**Comprehensive Test Station for**  
**The Lighting Association**  
**Code of Practice**

---



# **CLARE G2000**

## ***Comprehensive Test Station for The Lighting Association Code of Practice***

### **Operator Manual**

February 1999

© 1999 Clare Instruments Ltd.



<b>Section 1 – Notices</b>	<b>5</b>
Warranty	6
Copyright Notice	6
E & OE	6
Declaration of Conformity	7
<b>Section 2 - General Guidance Notes</b>	<b>9</b>
Safety	10
Safe Application of Test Equipment	11
Maintenance	12
Summary of Safety Information	13
<b>Section 3 - Introducing the CLARE G2000</b>	<b>15</b>
Front Panel Controls	16
Rear Panel Connections	19
Accessories	20
<b>Section 4 – Operating Procedures</b>	<b>23</b>
Instrument Set-Up	24
Test Procedure A – Basic Earthed (Class I) Products	27
Test Procedure B – Basic Double Insulated (Class II) Products	31
Test Procedure C – Earthed (Class I) Products plus Light-Up Test	35
Test Procedure D – Double Insulated (Class II) Products plus Light-Up Test	39



***Section 1***  
***Notices***

**Limited Warranty & Limitation of Liability**

CLARE Instruments Limited guarantees this product for a period of 1 year. The period of warranty will come into effect on the day of delivery.

**© Copyright 1999**

All rights reserved. Nothing from this edition may be multiplied, or made public in any form or manner, either electronically, mechanically, by photocopying, recording or in any manner without prior written consent from CLARE Instruments Limited. This also applies to any accompanying drawings, diagrams or illustrations.

**E&OE**

The information contained within this manual is given in good faith and is provided for guidance only. Although all reasonable care has been taken to ensure accuracy of the information, CLARE Instruments Limited, their agents and distributors, accept no responsibility for any errors or omissions within this document, nor for any misinterpretations by the user. For clarification on any part of this document please contact CLARE Instruments Limited, or your local agent, before operating the instrument.

Due to a policy of continuous development CLARE Instruments Limited reserve the right to alter or amend equipment specifications and descriptions outlined in this publication without prior notice. No part of this publication shall be deemed to form, or be part of, any contract for the equipment unless specifically referred to as an inclusion within such contract.



**Declaration of Conformity**

For the  
Clare G2000 Test Station

**Manufactured by:**

Clare Instruments Ltd. Dominion Way, Worthing, West Sussex. BN14 8NW

**Millennium Statement**

This product is Millennium compliant and conforms fully to the BSI DISC PD2000-1 document.

**Statement of Conformity**

Based on test results using appropriate standards, the product is in conformity with  
Electromagnetic Compatibility Directive 89/336/EEC and Low Voltage Directive 73/23/EEC.

**Standards Used:**

EN 61010-1 (1993) Safety Requirements for Electrical Equipment for Measurement, Control and Laboratory Use.

EN 50081-1 (1992) Electromagnetic Compatibility. Generic Emission Standard: EN55022 Class B.

EN 50082-1 (1992) Electromagnetic Compatibility. Generic Immunity Standard: IEC1000-4-2, -4-3, -4-4, -4-5.

The tests have been performed in a typical configuration.

Conformity is indicated by the symbol - , for 'Conformité Européenne'



**Section 2**  
**General Guidance Notes**

**SAFETY**

The design of the CLARE G2000 Test Station meets the European Commission Directive No. 73/23/EEC, relating to the "Low Voltage Directive". This is in accordance with BS EN 61010-1: 1993 – Safety requirements for electrical equipment for measurement control, and laboratory use. This unit is also compliant with the draft European Standard prEN 50191:1997.

The design of the equipment is intended for use under the following conditions:

Indoors;

Altitude up to 2000 m;

Temperature 5°C to 40°C;

Maximum relative humidity 80% for temperatures up to 31°C to 50% at 40°C;

Mains supply voltage fluctuations of  $\pm 10\%$  of the nominal voltage.

The user **MUST** follow the remainder of this section on safety, installation, guidance and maintenance to guarantee safe operation and to maintain the equipment in a safe condition.

**WARNING!** This equipment requires a protective earth conductor. Do not use the equipment without a protective earth conductor or intentionally interrupt the protective earth conductor.

**Do not remove or open the instrument cover** - When connected to the mains supply, internal terminals of the equipment will be live and the opening of covers or removal of parts is likely to expose live parts and create a risk of electrical shock. The user must disconnect the equipment from **ALL** voltage sources before any adjustment, replacement, maintenance or repair.

**Fuse Ratings** – For replacement purposes, the rated current and type of any internal, panel mounted or plugtop fuses, where fitted, must be as specified. Typically these will be of the Mains Quick Blow Type F style. The user must not use makeshift fuses or attempt to short-circuit fuse holders.

### **SAFE APPLICATION OF TEST EQUIPMENT**

Any person operating electrical test equipment must be 18 years old or over and should have had adequate training in the use of the particular piece of equipment. The degree of training should be appropriate for the competence and experience of the operator and should be documented.

Site the test equipment in a clearly defined test area, with access limited to the operator only. Where possible power outlet sockets should be of plastic construction and the test area should be free of steel conduit, trunking and such like. Construct test benches of insulated material, preferably wood. The operator must stand on an insulated, Earth free, surface such as British Standard approved rubber matting or nail-free duckboard. Provision should also be made to allow the test item to be placed on an insulated surface.

**DO NOT TOUCH OR CONTACT THE TEST ITEM WHILST OPERATING THE TEST EQUIPMENT.**

**KEEP THE TEST AREA CLEAN AND TIDY**

**MAINTENANCE**

Clare Instruments Ltd. supplies a guarantee against defective material and faulty manufacture for a twelve-month period from the date of delivery.

Prior to despatch the equipment undergoes careful inspection and comprehensive testing. Report any defect discovered with the equipment in respect of materials or workmanship within the guarantee period. We undertake to put right the defect at our expense subject to our standard conditions of sale.

Our responsibility is in all cases limited to the cost of making good the defect in the equipment. This does not apply to defects caused by abnormal conditions of working, accident, misuse, neglect or wear and tear.

In the event of difficulty or apparent malfunction, it is advisable to contact Clare Instruments Ltd. On –

Telephone 01903 502551 or Fax 01903 244258.

We recommend that the complete instrument be returned to us for repair or annual re-calibration:

The Service Department  
Clare Instruments Ltd  
Dominion Way  
WORTHING  
West Sussex  
BN14 8NW

Please take adequate care with packing and arrange insurance cover against transit damage or loss when returning the instrument – if possible use the original packing box and supports.

Regularly calibrate all test equipment to meet internal quality or regulatory licensing authority requirements and to keep the equipment in a safe working condition. Return the equipment to Clare Instruments for this purpose.

Keep the equipment in a clean condition. Examine all input and test output leads and connectors regularly to guarantee they are in a safe working condition.

The equipment contains parts that are specific to the equipment only, therefore, order spare parts from the above address. Clare Instruments Ltd. strictly forbid any use of spare parts, other than those acquired from the original manufacturer.

### **SUMMARY OF SAFETY INFORMATION**

Should there be any doubt about location, setting up procedure or operation of the test equipment, contact Clare Instruments Ltd. Report any apparent malfunctions immediately.

Maintain the test equipment in accordance with Health and Safety at Work Act and the Electricity at Work Regulations. The supply socket used for connection to the incoming mains system should undergo earth loop impedance measurements in keeping with the regulations to guarantee safe operation.

**NOTE:** Your Health and Safety Inspector may, with the benefit of on-site observations, offer alternate or additional instructions to the above recommendations.





**Section 3**  
***Introducing the CLARE G2000***

**Facia Controls and Indicators**

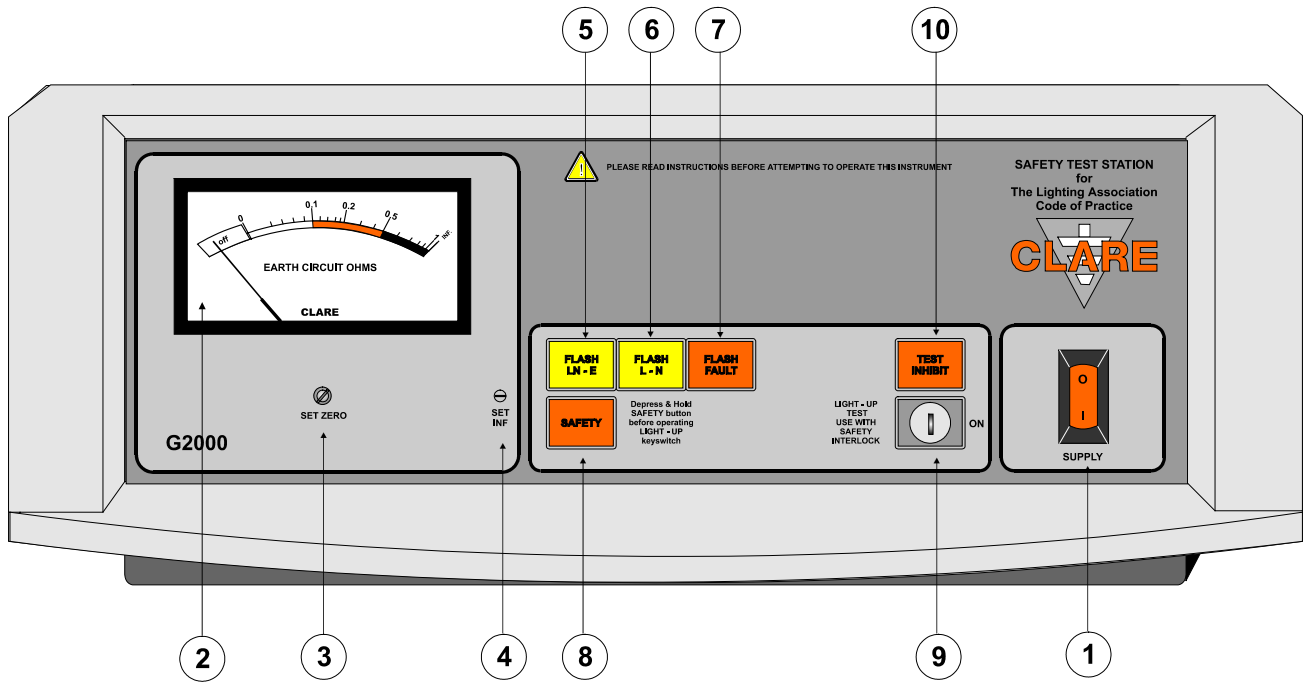

**FIG.1 Facia Controls & Indicators**

## **Descriptions**

1. **Supply Switch** - Rocker switch for switching the instrument on or off, illuminated in the ON position.
2. **Earth Circuit meter** – displays the ohmic value of the measured Earth path. A satisfactory reading will be below 0.5 ohms (in the amber or uncoloured zones). Readings in the red zone, or beyond, may indicate a poor or broken earth connection.
3. **Set Zero control** – used to set mechanical zero of the meter during factory build & calibration procedures. Not normally required for user adjustment.
4. **Set Inf. control** – used for setting the full scale (INF) reading of the meter to compensate for mains fluctuations, or differences, from location to location. Refer to Set-Up procedures for adjustment details.
5. **Flash LN-E push button** – used to apply 1500Va.c. Flash Test between Line + Neutral to Earthed parts for Class I products or, in conjunction with the Flash Probe, for applying 4000Va.c. between L + N to outer surfaces of Class II products.
6. **Flash L-N push button** – used to apply 1500Va.c. Flash Test between Line and Neutral circuits of both Class I and Class II products.

## **Note**

It is not advisable to apply a L-N Flash test to any product that requires a Light-Up test, particularly those that may incorporate electronic control circuits or in-line transformers, the test may damage sensitive electronic components. The Test Inhibit circuit should detect a L-N short and prevent the Light-Up test being applied.

7. **Flash Fault lamp** – lights to show that the product has failed the applied Flash test, an internal audible alarm will also sound and the test voltage will be removed automatically. This lamp also acts as the Fault Reset button, which must be momentarily depressed to cancel the fault indication and reset the safety trip circuit.
8. **Safety push button** – used in conjunction with the Light-Up test to minimize accidental operation.
9. **Light-Up test keyswitch** – applies mains voltage to the item under test, used as an alternative to the low voltage continuity/polarity test for products that include ballasts, filter networks, in-line transformers and the like, and therefore require full mains voltage to check correct operation.

THIS TEST SHOULD ONLY BE APPLIED FOLLOWING SATISFACTORY EARTH AND/OR FLASH TESTS.

10. **Test Inhibit lamp** – lights to indicate that internal protection circuitry has operated to prevent operation of the Flash or Light-Up tests. Check that Continuity probes have been removed from lamp holders and/or that total lamp load does not exceed 600 Watts.

### Rear Panel

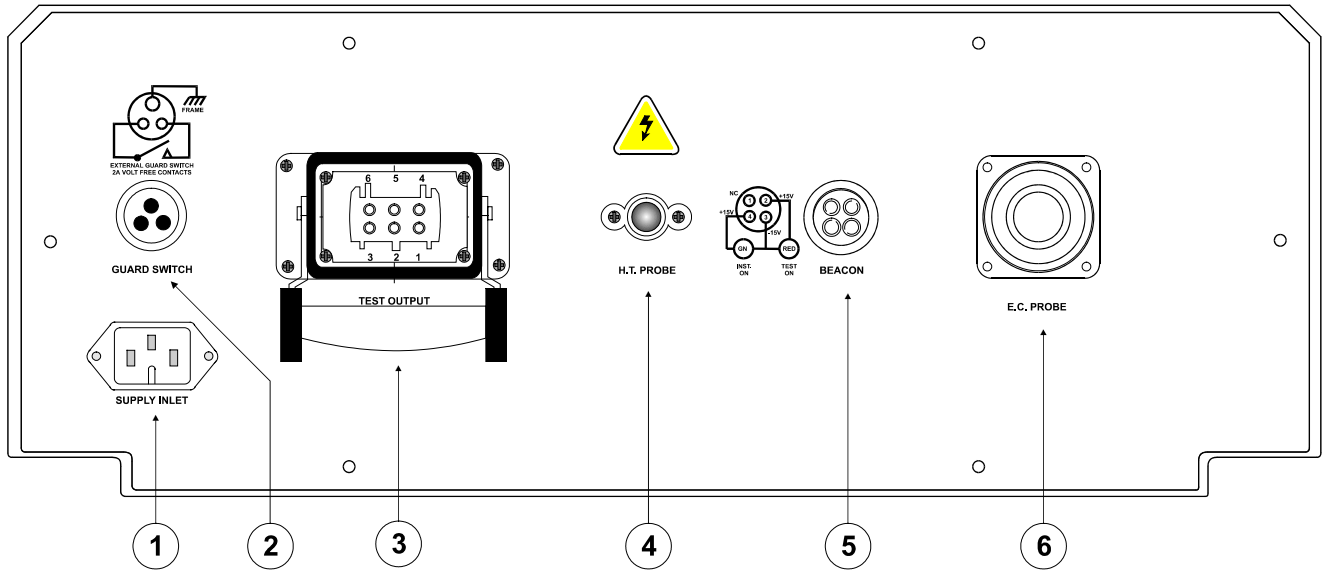
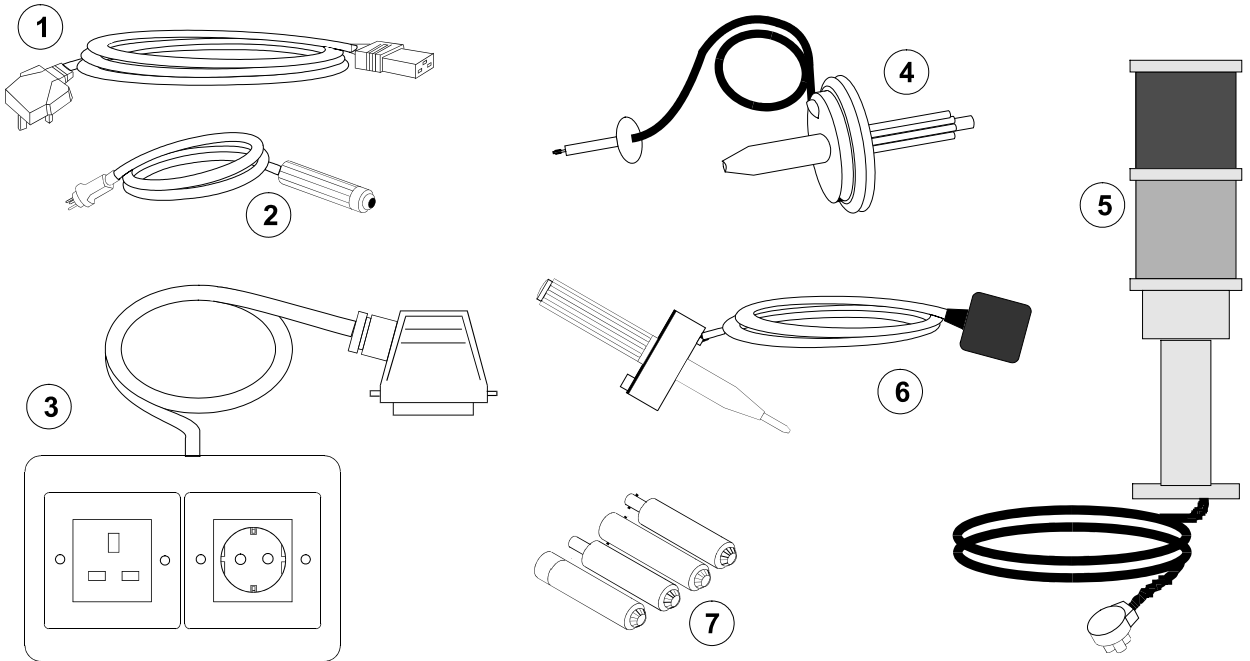

FIG.3 Rear Panel

Socket numbers illustrated, correspond with appropriate accessories detailed on the following pages

**Accessories**



**FIG.2 Accessories**

## **Descriptions**

1. **Mains lead** - 240V 13A plug to IEC connector – plug top fuse rated at 3A.
2. **Remote Safety Switch** – a push-button device used to promote two-handed operation when applying the high voltage Flash tests. Can be replaced by a Guard Interlock switch when using a safety enclosure.
3. **Test Outlet Box** – fitted with standard UK and European earthed sockets. An optional ‘Safebloc’ connector is also available for use with fittings wired with bare ended leads (ie. No plug fitted)
4. **Flash Test Probe** – a highly insulated safety probe used for applying the Flash test to Double Insulated (Class II) products. Depressing the red button on the probe handle exposes the test tip.
5. **Status Beacon** – used to provide visual indication of instrument status, Green light shows that the instrument is switched ON and ready for applying tests – Red light shows that a Flash test is in progress.
6. **Earth Probe** – a high current probe used for applying the Earth tests, the integral green lamp will light to show a satisfactory earth path. Check the meter reading for actual Earth resistance value.

Accessories 1-6 connect into sockets on the rear panel of the instrument, the appropriate sockets are correspondingly numbered in FIG.3 on the next page.

7. **Continuity Probes** – a set of low voltage lamp simulators for checking continuity and polarity of the wiring to individual lamp-holders. 4 separate probes supplied to suit Bayonet cap (BC) and Edison Screw (ES) fittings in both standard and small versions (SBC / SES) – other styles can be catered for at extra cost.





***Section 4***  
***Operating Procedures***

### **Instrument Set-Up**

1. Ensure that the text prior to this point, especially with regard to safety, is fully understood before proceeding.
2. Sight the instrument in accordance with the General Guidelines to promote ease of use and operator safety.

Clearly defined test area - limited access – insulated work surfaces – insulated matting – sufficient space for the product being tested – clean and tidy work area etc.

3. Connect all power, test probe leads and accessories into their respective rear panel connectors – if testing predominantly Earthed (Class I) items, it may be advisable to only connect the Class II Flash Probe when it is required.
4. Site and secure the Status Beacon where it can be clearly observed from outside the test area. Position the Test Output socket box and probe holders where they can be easily accessed by the operator.
5. Plug the power cord of the instrument into an Earthed 230V 50Hz socket outlet, preferably protected by a Residual Current Circuit Breaker (RCB) rated at no more than 30mA, and switch on the supply.
6. Operate the instrument's SUPPLY switch, the integral red lamp should light and the green lamp on the Status Beacon should also come on. At first switch on, operate the Flash Fault / Reset button once, to initialize tests.

7. **Earth test set up** – this may require the use of a small, flat bladed, screwdriver. With nothing connected to the Test Output sockets, apply the tip of the Earth Probe, using a firm steady pressure, to an insulated surface. This will activate the Earth test and the meter pointer should go hard over to the right of the meter scale and sit on the INF. mark. If it does, no adjustment is necessary.
8. If the pointer is not on the INF. mark, keep the pressure on the probe and then use the small screwdriver to adjust the SET INF. control on the front panel (see p.11 item 4), until the pointer does line up with the INF. mark. Release the probe.

**NOTE** – DO NOT adjust the SET ZERO control (p.11 item 3), this is factory set and should not be tampered with.

9. The instrument is now ready for product testing, follow the Test Procedure on the following pages relevant to the type of product -

**TEST PROCEDURE A** – (p.27) basic Earthed (Class I) Products with standard wiring

**TEST PROCEDURE B** – (p.31) basic Double Insulated (Class II) Products with standard wiring

**TEST PROCEDURE C** – (p.35) Earthed (Class I) Products requiring mains voltage Light-Up test

**TEST PROCEDURE D** – (p.39) Double Insulated (Class II) Products requiring mains voltage Light-Up test

Typically, the Light-Up test is only required for those products that incorporate ballasts, filter networks, in-line transformers and the like, and where the low voltage continuity/polarity test would not operate.



# ***Test Procedure A***

***Basic Earthed (Class I) Products***

**Visual Inspection**

10. Before applying any of the electrical tests, first inspect the product to ensure that all parts, including wiring, are mechanically sound and free from obvious defects or damage. Check also that cable restraints and switches, if fitted, are secure and functioning correctly.
11. Remove all lamps from the product and set any switches to the ON position.

**Continuity/Polarity Test**

12. Position and secure the product to be tested so that the lampholder(s) can be readily accessed and connect the power cord into the appropriate socket on the Test Output box (or into the optional Safebloc if fitted). If the TEST INHIBIT lamp comes on straight away, the product may have a wiring short circuit – investigate and correct before proceeding.
13. Fit the appropriate Lamp Simulator probe into the lampholder (the ES and SES probes need to be held depressed in the holder) and check that the simulator light glows – The Test Inhibit lamp will also come on. For luminaires fitted with switches, operate the switch 2 or 3 times and check that the simulator and Inhibit lamps go on and off accordingly. Repeat the test at all other lampholders on the product as necessary. Remove the simulator (and leave any switches in the ON position) before applying any other tests.
14. If the simulator fails to light, during the above test sequence, suspect product wiring. No further testing should be applied to the product until the fault has been located and corrected.

**Earth Continuity Test**

- 15.** Firmly apply the Earth Probe, for 3 - 6 seconds, to all exposed, unpainted, metalwork on the product in turn and check that the green PASS lamp on the probe lights and the Earth Circuit meter reads below 0.5 ohms, i.e. within the un-coloured or orange bands, at each test point.
- 16.** Take particular care, with multi-branch luminaires, to test each branch fully – paying particular attention to exposed metal that is furthest from the Earthing terminal, to ensure that joints between base / arm / shade etc are fully sound.
- 17.** For products with exposed brass lampholders also make sure that these are tested – do not apply the probe to either of the live pins.
- 18.** Following a satisfactory test, release the probe and stow it out of the way in the holder provided.
- 19.** If the green PASS lamp fails to come on, or remain on, whilst the test is applied, the Earth resistance exceeds the permitted 0.5 Ohms – the meter pointer will be in or above the red zone.

This may be caused by - loose / broken earth wires - loose or corroded joints - applying the probe to lacquered surfaces, or making poor contact - even missing Earth wires. Correct any faults before continuing.

**Flash Tests – LN-E and L-N**

20. Check that the TEST INHIBIT lamp is off – if it's on, check that no Lamp Simulators have been left plugged into any of the lampholders.

**DO NOT TOUCH, HOLD OR COME INTO CONTACT WITH THE PRODUCT WHEN APPLYING FLASH TESTS**

21. Hold the remote Safety switch in one hand and depress (and hold in) the button on the end, then, with the other hand, depress the panel mounted LN-E test button, for 2 seconds. The red FLASH FAIL lamp and internal audible alarm should remain off. Release both buttons.
22. Now apply the L-N test in a similar manner - operate remote Safety switch with one hand and then depress the L-N panel button with other hand - again the FAIL lamp and alarm should remain off.
23. **If the FAIL lamp and alarm come on, a flashover has occurred or the leakage current exceeds the permissible level. Release the Safety and test buttons, then momentarily depress the Flash Fault / Reset button to reset the fault indications.**

Investigate and correct any indicated faults and then fully re-test the product. When all test results are satisfactory testing is complete.



# ***Test Procedure B***

***Basic Double Insulated (Class II) Products***

**Visual Inspection**

24. Before applying any of the electrical tests, first inspect the product to ensure that all parts, including wiring, are mechanically sound and free from obvious defects or damage. Check also that cable restraints and switches, if fitted, are secure and functioning correctly.
25. Remove all lamps from the product and set any switches to their ON position.

**Continuity/Polarity Test**

26. Position and secure the product to be tested so that the lampholder(s) can be readily accessed and connect the power cord into the appropriate socket on the Test Output box (or into the optional Safebloc if fitted). If the TEST INHIBIT lamp comes on straight away, the product may have a wiring short circuit – investigate and correct before proceeding.
27. Fit the appropriate Lamp Simulator probe into the lampholder (the ES and SES probes need to be held depressed in the holder) and check that the simulator light glows – The Test Inhibit lamp will also come on. For luminaires fitted with switches, operate the switch 2 or 3 times and check that the simulator and Inhibit lamps go on and off accordingly. Repeat the test at all other lampholders on the product as necessary. Remove the simulator (and leave any switches in the ON position) before applying any other tests.
28. If the simulator fails to light, during the above test sequence, suspect product wiring. No further testing should be applied to the product until the fault has been located and corrected.

**Flash Tests – LN-Outer Surfaces and L-N**

29. This test will require use of the safety Flash Probe – if it isn't already connected into the rear panel socket, plug it in before proceeding
30. Check that the TEST INHIBIT lamp is off – if it's on, check that no Lamp Simulators have been left plugged into any of the lampholders. Check that the test item is secure and stable and cannot move about.

**DO NOT TOUCH, HOLD OR COME INTO BODILY CONTACT WITH THE ITEM WHEN FLASH TESTING**

31. Hold the remote Safety switch in one hand and depress (and hold in) the button on the end. With the same hand, depress the panel mounted LN-E test button. With the other hand pick up the red Flash probe and expose the test tip by depressing the red button on the handle.
32. Apply the probe tip to any metal trims on the product and over all outer surfaces of the product, paying particular attention around body joint-lines, switches, lampholders, cable entries etc. to check that there are no protruding wire ends etc. The red FLASH FAIL lamp and internal audible alarm should remain off. Release both the remote Safety button and the LN-E button. Stow the probe safely away.
33. Now apply the L-N test (this test doesn't require the probe) - operate the remote Safety switch with one hand and then depress the L-N panel button with other hand - again the FAIL lamp and alarm should remain off.
34. **If the FAIL lamp and alarm come on, a flashover has occurred or the leakage current exceeds the permissible level. Release the Safety and test buttons, then momentarily depress the Flash Fault / Reset button to reset the fault indications.**



# ***Test Procedure C***

***Earthed (Class I) Products plus Light-Up test***

**Visual Inspection**

35. Before applying any of the electrical tests, first inspect the product to ensure that all parts, including wiring, are mechanically sound and free from obvious defects or damage. Check also that cable restraints and switches, if fitted, are secure and functioning correctly.
36. Remove all lamps from the product and set any switches to their ON position.

**Earth Continuity Test**

37. Firmly apply the Earth Probe, for 3 - 6 seconds, to all exposed, unpainted, metalwork on the product in turn and check that the green PASS lamp on the probe lights and the Earth Circuit meter reads below 0.5 ohms, i.e. within the un-coloured or orange bands, at each test point.
38. Take particular care, with multi-branch luminaires, to test each branch fully – paying particular attention to exposed metal that is furthest from the Earthing terminal, to ensure that joints between base / arm / shade etc are fully sound.
39. For products with exposed brass lampholders also make sure that the lampholder itself is tested – do not apply the probe to either of the live pins.
40. Following a satisfactory test, release the probe and stow it out of the way in the holder provided.

41. If the green PASS lamp fails to come on, or remain on, whilst the test is applied, the Earth resistance exceeds the permitted 0.5 Ohms – the meter pointer will be in or above the red zone.

This may be caused by - loose, broken or even missing Earth wires - loose or corroded joints - applying the probe to lacquered surfaces, or making poor contact with the probe. Correct any faults before continuing.

**Flash Test – LN-E**

**Note** - It is not advisable to apply a L-N Flash test to any product that requires a Light-Up test, particularly where damage may be caused to sensitive electronic control circuits or in-line transformers. The Test Inhibit circuit should detect a L-N short and prevent the Light-Up test being applied.

42. Check that the TEST INHIBIT lamp is off – if it's on, check that no Lamp Simulators have been left plugged into any of the lampholders.

**DO NOT TOUCH, HOLD OR COME INTO CONTACT WITH THE PRODUCT WHEN APPLYING FLASH TESTS**

43. Hold the remote Safety switch in one hand and depress (and hold in) the buttons on the end, then, with the other hand, depress the panel mounted LN-E test button, for 2 seconds. The red FLASH FAIL lamp and internal audible alarm should remain off. Release both buttons.

44. **If the FAIL lamp and alarm come on, a flashover has occurred or the leakage current exceeds the permissible level. Release the Safety and test buttons, then momentarily depress the Flash Fault / Reset button to reset the fault indications.**

Investigate and correct any indicated faults and then fully re-test the product before proceeding.

**Light-Up Test**

45. Fit appropriate lamps into the product, making sure not to exceed a maximum of 600W loading.
46. Ensure product switches are set to the ON position.
47. Ensure the TEST INHIBIT lamp is not on – if it is, check that the lamp loading is not excessive or disconnect the product and check for any sources of short circuit in the wiring.
48. Depress the panel mounted SAFETY button and hold it in, then turn the Light-Up Test keyswitch to the ON position and hold it there. The lamps in the product should light. If not, suspect a faulty lamp. Release the keyswitch and SAFETY button.

**WARNING**

ONLY APPLY THE LIGHT-UP TEST ONCE – do not keep flicking the switch on and off as this may cause nuisance tripping of the supply RCB.



# ***Test Procedure D***

***Double Insulated (Class II) Products plus Light-Up test***

**Flash Test – LN-Outer Surfaces**

**Note** – It is not advisable to apply a L-N Flash test to any product that requires a Light-Up test, particularly those that may incorporate electronic control circuits or in-line transformers. The Test Inhibit circuit should detect a L-N short and prevent the Light-Up test being applied.

49. This test will require use of the safety Flash Probe – if it isn't already connected into the rear panel socket, plug it in before proceeding
50. Check that the TEST INHIBIT lamp is off – if it's on, check that all lamps have been removed from the product and that there are no apparent L-N short circuits.

**DO NOT TOUCH, HOLD OR COME INTO CONTACT WITH THE PRODUCT WHEN APPLYING FLASH TESTS**

51. Hold the remote Safety switch in one hand and depress (and hold in) the button on the end. With the same hand, depress the panel mounted LN-E test button. With the other hand pick up the red Flash probe and expose the test tip by depressing the red button on the handle.
52. Apply the probe tip to any metal trims on the product and over all outer surfaces of the product, paying particular attention around body joint-lines, switches, cable entries etc. to check that there are no protruding wire ends etc. The red FLASH FAIL lamp and internal audible alarm should remain off. Release both the remote Safety button and the LN-E button. Retract the tip of the probe and stow the probe safely away.

53. If the FAIL lamp and alarm come on, a flashover has occurred or the leakage current exceeds the permissible level. Release the Safety and test buttons, then momentarily depress the Flash Fault / Reset button to reset the fault indications.

Investigate and correct any indicated faults and then fully re-test the product before proceeding.

**Light-Up Test**

54. Fit appropriate lamps into the product, making sure not to exceed a maximum of 600W loading.
55. Ensure product switches are set to the ON position.
56. Ensure the TEST INHIBIT lamp is not on – if it is, check that the lamp loading is not excessive or disconnect the product and check for any sources of short circuit in the wiring.
57. Depress the panel mounted SAFETY button and hold it in, then turn the Light-Up Test keyswitch to the ON position and hold it there. The lamps in the product should light. If not, suspect a faulty lamp. Release the keyswitch and SAFETY button.

**WARNING**

ONLY APPLY THE LIGHT-UP TEST ONCE – do not keep flicking the switch on and off as this may cause nuisance tripping of the supply RCB.

END



**CLARE**  
INSTRUMENTS LTD.

**CLARE INSTRUMENTS LTD**

Dominion Way • WORTHING • West Sussex • England • BN14 8NW

Tel: +44 (0)1903 233 314 • Fax: +44 (0)1903 216 089

e-mail :[sales@clareinstruments.com](mailto:sales@clareinstruments.com) • Website: [www.clareinstruments.com](http://www.clareinstruments.com)

Registered Office: 18 Bracken Hill . South West Industrial Estate . PETERLEE . County Durham . England . SR8 2JJ . Registered in England No. 1027434